

■ ■ Product User Manual

Please read the manual carefully before operation



Email: techsupport@xdbattery.com

Manufacturer: Beijing XD Battery Technology Co., Ltd

Add: Building 13, No.5 Tianhua Street,

Daxing district, Beijing, China

Email: techsupport@xdbattery.com

www.xdbattery.com

<https://xdbattery.en.alibaba.com>

Information Version: 1.0

CATALOG

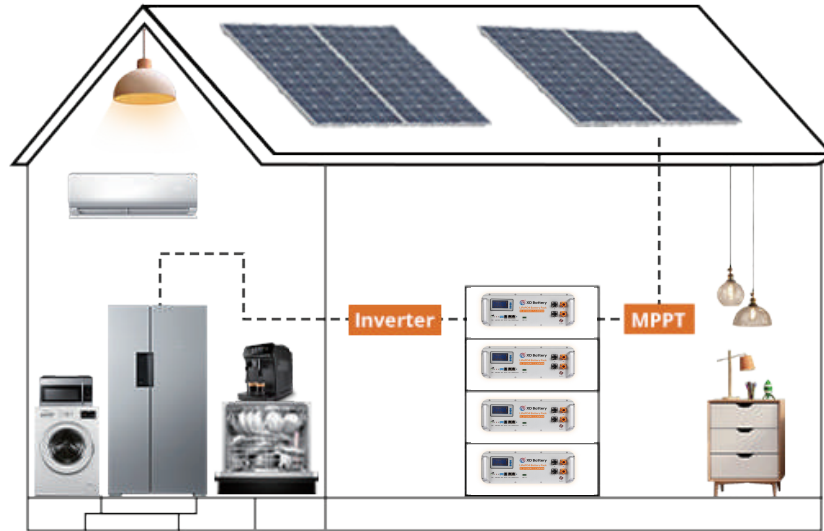

Please comply with all warnings and operating instructions in this manual strictly. Save this manual properly and read carefully the following instructions before installing the unit.

Do not operate this unit before reading through all safety information and operating instructions carefully.

1. Safety Precautions	1
1.1 Reminding	1
1.2 Charging	1
1.3 Discharging	1-2
1.4 Load Power	2
1.5 Series and parallel connections	2
2. Introduction	3
2.1 Performance characteristics	3
2.2 Specification	3-5
2.3 Symbol description	5
2.4 Device interface description	5-13
2.5 Introduction to BMS	13-14
3. Safe Handling Of lithium Batteries Guide	15
3.1 Danger label	15
3.2 Tools	15
3.3 Safety gear	15-16
4. Installation And Operation	16
4.1 1Package items	16-18
4.2 Installation location	18
4.3 Grounding requirements	18
4.4 Installation steps	19-23
4.5 Display description	23-28
4.6 Power on	28
4.7 Power off	28-29
5. Trouble Shooting	29
5.1 Problem determination based on	29
5.2 Possible conditions	29-31
6. Emergency Situations	31
6.1 Leaking batteries	31
6.2 Fire	31
6.3 Wet batteries	31
6.4 Damaged batteries	31
7. Remarks	32
7.1 Recycle and disposal	32
7.2 Maintenance	32

1. SAFETY PRECAUTIONS

⚠️ 1.1 SAFETY PRECAUTIONS

Please observe the following safety rules when using batteries. Abuse of batteries can lead to overheating, bulging and fire of batteries and cause serious damage.

- * DO **NOT** disassemble or modify the battery.
- * DO **NOT** short circuit positive and negative terminals.
- * DO **NOT** puncture, drop, crush, burn, penetrate, shake, or strike the battery.
- * DO **NOT** expose to the environment, this battery is not sealed. Please keep the battery away from water, heat sources, sparks, and hazardous chemicals.
- * DO **NOT** dispose of the battery as household waste. Please use recycling channels in accordance with local, state, and federal regulations.
- * Only charge the battery with a battery charger or charge controller that is compatible with lithium iron phosphate batteries.
- * If the battery shuts off due to a low state of charge, please disconnect the battery from your equipment to eliminate parasitic loads and charge the battery as soon as possible.
- * Please wear proper protective equipment when working on the battery.
- * Please use insulated tools when working on the battery.
- * Please keep the battery out of the reach of young children.
- * Please use suitable handling equipment for safe transportation of the battery.

⚠️ 1.2 CHARGING

Only charge the battery with a battery charger (56.8V) or charge controller that is compatible with lithium iron phosphate batteries. For charging current, please check the battery specification in this manual according to the product model.

- * DO **NOT** exceed the maximum charge current of the battery.
- * Fully charge the battery before first use.
- * The SOC (State Of Charge) on the display is the remaining power.
- * LiFePO4 does not suffer a "memory effect" so please keep the battery fully charged for daily use.
- * Do not charge the battery at temperatures below 0°C. This can cause damage to the battery cells.

⚠️ 1.3 DISCHARGING

Make sure your load accepts the 51.2V nominal voltage and does not exceed the maximum discharge current of the battery.

- * Ensure the connection between the battery and the load can handle the current draw. Please consult references for the appropriate wire type.
- * DO **NOT** connect large loads to the battery when it is running low.
- * The battery output voltage is 51.2V, operating voltage range 43.2V - 57.6V, Do **NOT** rely on voltage as an indicator of remaining capacity.
- * If the battery shuts down due to a low charge (SOC), disconnect the battery from the load to eliminate potential parasitic loads and charge the battery as soon as possible. Failure to do so may cause irreversible damage to the battery.

⚠️ 1.4 LOAD POWER

1 battery pack of this type, supporting load rated power <5KW,
2-4 battery packs of this type in parallel, support load rated power <5KW, or 6KW high power discharge <1 hour.

If your load power exceeds 6KW, please contact our technical support.

⚠️ 1.5 SERIES AND PARALLEL CONNECTIONS

Each battery pack must be fully charged independently before connecting. Please make sure that the voltage difference of each battery pack is within 0.3V before connecting in parallel. All batteries should be at the same charge level prior to connection or you will experience balancing problems in your system.

- * DO **NOT** connect batteries in series!
- * If you need more than 4 batteries in parallel. Please contact our customer service and we will give you professional guidance.
(This model can be connected with up to 16 units 51.2V100Ah batteries in parallel. Parallel Connecting Total voltage and capacity: 51.2V 1600Ah.)
- * **Attention!** All cables and connections must be able to accommodate the high currents that can be supplied by the battery. The use of appropriate fuses and circuit breakers is highly recommended to protect downstream components from current spikes and short circuits.
- * In parallel battery banks, the cables between each battery should be of equal length to ensure that all batteries in the system can work equally together.
- * To connect multiple batteries in parallel, first connect the positive terminals of the batteries to each other. Then do the same thing for the negative terminal. After the above connections are made, connect the positive and negative terminals of the first battery to the system. This type of arrangement is used to increase the overall battery capacity while maintaining the same voltage.
- * DO NOT string batteries with different chemistries, models, rated capacity in series or parallel.

2. INTRODUCTION

51.2V100Ah energy storage system is a series of communication backup power products of LiFePO4 battery designed, developed, produced and sold by Aolithium. This system is an intelligent unattended backup power system, which is suitable for small capacity home storage equipment, remote switch, mobile communication equipment, transmission equipment, satellite earth station and microwave communication equipment, etc. It has the functions of centralized control, battery maintenance and management, and meets the requirements of unattended.

2.1 PERFORMANCE ADVANTAGES

- 1) The energy storage system realizes energy storage for customers and avoids business interruptions in the communication system due to power outages.
- 2) Rack-mounted design supports parallel expansion, high energy density battery products achieve the same energy supply in a smaller volume, minus Less space occupation for the computer room.
- 3) Using the BMS management system dedicated to communication lithium batteries, it can monitor the voltage of all single cells in the battery pack in real time, the total current, total voltage, ambient temperature and other parameters of the battery pack, and has a number of protection functions such as preventing battery overcharge and overcharge, which can improve battery utilization efficiency and extend battery life.
- 4) High-energy, low-power lithium battery equipment to achieve higher energy supply, lower energy consumption, and reduce environmental pollution.
- 5) All-round and multi-level battery protection strategies and fault isolation measures are adopted to ensure the safe operation of the energy storage system.

2.2 SPECIFICATION

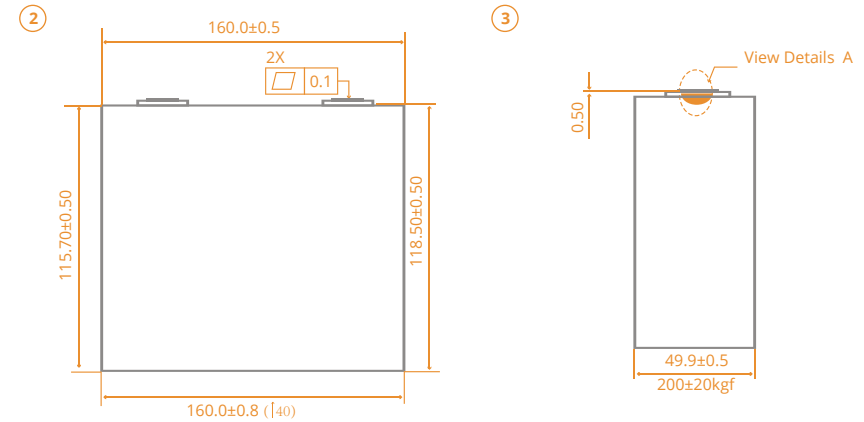
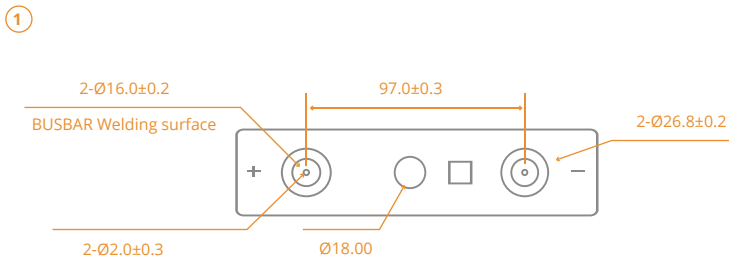









Serial number	Project name	Technical parameters	Remark
1	Rated capacity	100A	Lithium iron phosphate
2	Rated voltage	3.2V	
3	Operating voltage	2.0-3.65V	
4	Size	(49.9±0.5)*(160±0.5)*(118.5±0.3)	mm
5	Weight	(1.98±0.05)kg	
6	Rated energy	320Wh	

The core is 3.2V/100Ah lithium iron phosphate battery, with high safety, long cycle life, superior multiplier charge and discharge performance, green non-pollution and other four characteristics, its main technical parameters:

Basic Parameters	parameters
Nominal Voltage (V)	51.2
Rated Capacity (Wh)	5120
Usable Capacity (Wh)	4608
Dimension (mm)	488*578*177.8mm
Weight (Kg)	<50kg
Discharge Voltage (V)	43.2-57.6
Recommend Charge/Discharge Current (A)	50/100
SOC operating range	15%-95%
Communication	RS485, CAN

Charge and discharge efficiency	≥95%
Grouping scenarios	1P16S
Charging temperature range	0°C~55°C
Discharge temperature range	-20°C~60°C
Optimal storage temperature	-10°C-30°C
IP rating of enclosure	IP43
Cooling method	Free cooling
Ambient humidity	5%-95%
Self-discharge rate/month	≤3%
Design Life	>3000 (@25°C, 85%DOD)
color	White
Rated capacity: test conditions, battery cell 2.5~3.65V, 25±3°C temperature range, 0.5C charge 1C discharge.	
Rated Capacity (Wh): Test conditions, cell 2.5 ~ 3.65V, 25 ± 3 °C temperature range, 0.5C charge and 1C discharge.	

2.3 SYMBOL DESCRIPTION





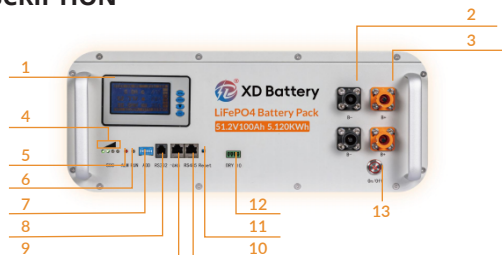

Symbol	Description
	Do not place near open flames or flammable materials.
	A potential hazard exists when the equipment is working. Wear personal protective equipment during operation.
	High voltage danger. Power off the equipment before any operations.
	Grounding. : To indicate PE cable connection position.
	Do not place in areas accessible to children.
	Keep the battery away from open flame or ignition sources.
	Read the instructions.
	Do not disconnect or disassemble by non professionals.

2.4 DEVICE INTERFACE DESCRIPTION



NO.	Name	Uses
1	Display	Battery operation interface
2	Negative socket	Negative side of the battery
3	Positive socket	Positive terminal of the battery
4	SOC indicator	Display of remaining charge
5	ALM indicator	Fault indicator
6	Run operation indicator	Operation indicator
7	ADD address dip switch	Battery address code switch
8	RS485/CAN interface	Communication interface, 500 Kbps, for inverters.
9	RS485B interface	Communication interface, 9600 bps, For connection to inverter.
10	RS485 interface	Communication interface, 9600 bps, For connection to inverter.
11	Reset restart key	Reset recovery key
12	DRY10	Switch output key
13	ON/OFF power on/off key	Power on/off key

1) LED indicator definition LED

SOC4	SOC3	SOC2	SOC1		
					
				ALM	RUN

The red LED light is an alarm indicator, and the alarm indicator flashes to indicate that the battery is faulty; Solid light shows that the battery is in a failsafe state and cannot be used, notify the manufacturer or professional engineer to debug or repair. (See LED indicator table for details).

SOC:

The green LED is an operational indicator. Under the SOC function area, use the 4 operating LEDs to display the remaining capacity of the battery.

LED indication form:

State	Charge				Discharge			
Capacity indicator	SOC4 ●	SOC3 ●	SOC2 ●	SOC1 ●	SOC4 ●	SOC3 ●	SOC2 ●	SOC1 ●
0~25%	Blink 2	Extinguish	Extinguish	Extinguish	Always on	Extinguish	Extinguish	Extinguish
25~50%	Always on	Blink 2	Extinguish	Extinguish	Always on	Always on	Extinguish	Extinguish
50~75%	Always on	Always on	Blink 2	Extinguish	Always on	Always on	Always on	Extinguish
75~100%	Always on	Always on	Always on	Blink 2	Always on	Always on	Always on	Always on
Run LED ●	Always on				Flashing 3			

Status indication table:

System status	Unusual events	Electricity LED				ALM	RUN	Remark
		●	●	●	●			
Shutdown	Shut down/ hibernate						All extinguished	
Standby	Normal					●	Flash 1	When standby, only normal and alarm, protection and fault are reported according to the charge and discharge status; The alarm includes the following categories, large voltage difference alarm, low capacity alarm, high and low monomer voltage, high and low overall voltage, and all temperature alarms (cell temperature is high, low, ambient temperature is high, low, MOS temperature is high. (ALM does not flash when monomer & total voltage overvoltage alarm).
	Alarm					●	Flash 2	
Charge	Normal					●	Always on	Alarms include the following categories, large voltage difference alarm, low capacity alarm, high and low monomer voltage, high and low overall voltage, all temperature alarms (high cell temperature, low ambient temperature, low ambient temperature, high MOS temperature; Overcurrent alarm. (ALM does not flash when monomer & total voltage overvoltage alarm).
	Alarm					●	Always on	
	Monomer /integral overvoltage protection/ full charge protection					●	Flash 2	
	Overcurrent protection					●	Always on	
	(Enter current limit charge)					●	Always on	
Temperature protection					●	Extinguish	Cell, MOS, environment.	

	Normal	According to the battery level indication	Extinguish	Flash 3	Alarms include the following categories, large voltage difference alarm, low capacity alarm, high and low monomer voltage, high and low overall voltage, all temperature alarms (cell temperature is high, low, ambient temperature is high, low MOS temperature is high; Overcurrent alarm.	
	Discharge		Alarm	Flash 2		Flash 3
Monomer/ overall undervoltage protection			Flash 2	Extinguish		
Overcurrent and short-circuit protection			Extinguish	Always on		Extinguish
Temperature protection			Extinguish	Always on		Extinguish
Fault	NTC fault, MOS fault, reverse polarity, differential voltage protection, ultra-low voltage protection	Extinguish	Always on	Extinguish		

2) Blinking instructions

Blinking mode	Bright	Extinguish
Flash1	0.25S	3.75S
Flash2	0.5S	0.5S
Flash3	0.5S	1.5S

Power Terminals

Power cable terminals: there are two pair of terminals with same function, one connects to equipment, the other one paralleling to other battery module for capacity expanding.

For power cables uses water-proofed connectors. must keep pressing this Lock Button while pulling out the power plug.

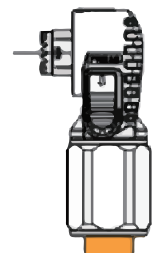

Communication

(1) RS485/CAN communication

This communication interface communicates with PCS.



RS485/CAN communication interface

- ① The BMS can communicate with the inverter through the CAN interface, and can upload various information of the battery, such as voltage, current, temperature, SOC, SOH, working status and other information. The default baud rate is 500Kbps.
- ② CAN port inverter communication protocol selection.
- ③ The BMS is a host mode CAN to communicate with the inverter and achieve protocol switching through DIP5 and 6.

Communication interface definition

EMS communication port (host computer communication)	
RS485A—Uses 8P8C vertical RJ45 socket	
RJ45 pin	Define a descriptio
1 / 8	RS485-B1
2 / 7	RS485-A1
4	CANH
5	CANL
6	GND

(2) RS485B communication

Two RS485B communication interfaces are used to realize the parallel function, communication between slave and slave, and communication between master and slave.



RS485B communication interface

- ① The BMS can communicate with the host computer via the RS485 communication interface.
- ② With RS485 parallel interface, it can support up to 16 battery packs and a default baud rate of 9600bps.
- ③ It has inverter communication RS485 interface and the default baud rate is 9600bps.

Communication interface definition

Parallel communication port (only used for paralleling)			
RS485-2—Vertical RJ45 socket		RS485-2—Uses 8P8C vertical RJ45 socket	
RJ45 pin	Define a description	RJ45 pin	Define a description
1 / 8	RS485-B2	1 / 8	RS485-B2
2 / 7	RS485-A2	2 / 7	RS485-A2
6	GND	6	GND

RS485B communication interface definition

Parallel wiring method

The battery pack is connected to the RS485 bus in parallel, and can also communicate with devices with RS485 bus, while the CAN interface realizes communication with PCS or other intelligent terminals. The PC host computer reads any battery pack information connected in parallel with the RS485 bus.

Parallel cable: The network cable connected from the master to the slave uses a standard network cable.

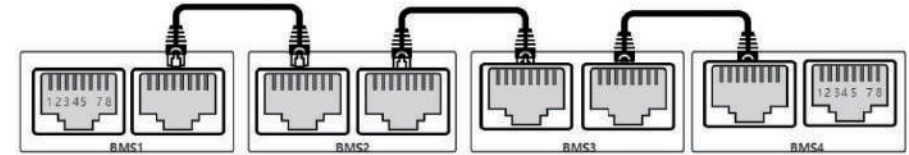

BMS board parallel connection method BMS

Weak current switch (self-locking)

Weak current switch and close, BMS normal operation; The weak current switch is disconnected and the BMS performs shutdown.



Weak current switch

Reset button

Press and hold the button to reset the BMS in software or hardware and clear various abnormal states.



Reset button



Power outlets

The power connection consists of 2 parallel positive sockets and 2 parallel negative sockets.



Power outlets

DIP switch settings

When performing multi-machine parallel communication operations, you need to configure the dialing address of each PACK first. The dialing code adopts BCD code format, address is defined as 0  (The black dot is the dialing location, the same below), address 1  address 2  Binary, other addresses, and so on.

BMS can communicate with the inverter in host mode CAN, and protocol switching is realized through DIP5 and 6.

Slave settings: Set according to the order of devices, slave address range 0 to 15, 16 parallel units.



Address	DIP switch position						Obligate	Host	Illustrate
	#1	#2	#3	#4	#5	#6			
0	OFF	OFF	OFF	OFF	OFF	OFF	OFF	(Host)	
1	ON	OFF	OFF	OFF	OFF	OFF	OFF	(Slave)Pcak1	
2	OFF	ON	OFF	OFF	OFF	OFF	OFF	(Slave)Pcak2	
3	ON	ON	OFF	OFF	OFF	OFF	OFF	(Slave)Pcak3	
4	OFF	OFF	ON	OFF	OFF	OFF	OFF	(Slave)Pcak4	
5	ON	OFF	ON	OFF	OFF	OFF	OFF	(Slave)Pcak5	
6	OFF	ON	ON	OFF	OFF	OFF	OFF	(Slave)Pcak6	
7	ON	ON	ON	OFF	OFF	OFF	OFF	(Slave)Pcak7	
8	OFF	OFF	OFF	ON	OFF	OFF	OFF	(Slave)Pcak8	
9	ON	OFF	OFF	ON	OFF	OFF	OFF	(Slave)Pcak9	
10	OFF	ON	OFF	ON	OFF	OFF	OFF	(Slave)Pcak10	
11	ON	ON	OFF	ON	OFF	OFF	OFF	(Slave)Pcak11	
12	OFF	OFF	ON	ON	OFF	OFF	OFF	(Slave)Pcak12	
13	ON	OFF	ON	ON	OFF	OFF	OFF	(Slave)Pcak13	
14	OFF	ON	ON	ON	OFF	OFF	OFF	(Slave)Pcak14	
15	ON	ON	ON	ON	OFF	OFF	OFF	(Slave)Pcak15	

Inverter communication protocol selection CAN communication (selected in host mode via dials 5 and 6)

0	OFF	OFF	OFF	OFF	OFF	OFF	VICTRON/SMA
32	OFF	OFF	OFF	OFF	OFF	ON	Pineng Deye and so on
16	OFF	OFF	OFF	OFF	ON	OFF	Obligiate
48	OFF	OFF	OFF	OFF	ON	ON	Gorwatt

Inverter communication protocol selection RS485 communication (selected by dialing 5 and 6 in host mode)

1	ON	OFF	OFF	OFF	OFF	OFF	Sun Moon Yuan
32	OFF	OFF	OFF	OFF	OFF	ON	Shuo Ri
48	OFF	OFF	OFF	OFF	ON	ON	Obligiate
16	OFF	OFF	OFF	OFF	ON	OFF	Rylon

Matching inverters: CAN: Pylontech, Deye, Goodway, Growatt, Jinlong, Pengcheng, Victron, Sofar, SMA, etc; RS485: Voltronic, etc; Communication protocol used: Pylon-CAN-V1.2-180408-lowVoltage; Growatt BMS CAN-Bus-protocol-low-voltage-V1.05; Victron-Victor-CAN-V1.00-220910; Voltronic-485-V1.0.3-200325; WOW-protocol-Shuori-V1.3; Co San BMS_Protocol_V1_0_0.

Inverter	Communication Method	Agreement	Remarks	Baud Rate	Inverter Interface Definition	BMS Interface Definition	BMS Dialing Code	Inverter Setting
Growatt	CAN	Growatt BMS CAN-Bus-protocol-lowvoltage V1.05	Active Upload	500K	4H、5L	4H、5L	56 on	Master Slave
Goodwe	CAN	Goodwe-CAN-V17-220228 SolarInverterFamily-EN	Active Upload	500K	4H、5L	4H、5L	06 on	Master Slave
Voltronic	485	Voltronic-Sacolar-485-V1.0.3-20035	MODBUS	9600	3B、5A	1B、2A	100 on	Stand Alone
Sofar	CAN	Sofar-CAN-V1.00-211117-Rev6	Active Upload	500K	1H、2L	4H、5L	00 on	Master Slave
Sorotec	CAN	CAN Protocol 10 (Ryder CAN Protocol)	Active Upload	500K		4H、5L	06 on	Master Slave
Deye	CAN	Deye LV-CAN communication protocol	Active Upload	500K	4H、5L	4H、5L	06 on	Master Slave
Ginlong	CAN	Solis-ginlong-CAN-V10-191228-lovVoltage	Active Upload	500K	4H、5L	4H、5L	06 on	Master Slave
Pylontech	CAN	Pylon-CAN-V1.2-180408 lowVoltage	Active Upload	500K		4H、5L	06 on	Master Slave
Sol-Ark	CAN	Sol-Ark CANBus Protocol V1.2.pdf 4-25-22	Active Upload	500K		4H、5L	06 on	Master Slave
SMA	CAN	SMA-CAN V1.0.0-210630-FSS ConnectingBat-TI-en-20w	Active Upload	500K	4H、5L	4H、5L	00 on	Master Slave
MPP Sola	485	BMS 485communication protocol20200325(2)	MODBUS	9600		1B、2A	56 on	Stand Alone
Senergy	CAN	SenergyINV&BMS CAN Protocols	Active Upload	500K	7H、8L	4H、5L	06 on	Master Slave
Senergy	CAN	Victron-CAN-V1.00-211135	Active Upload	500K	7H、8L	4H、5L	00 on	Master Slave

Sol-Ark	CAN	Sol-Ark CANBus Protocol V1.2.pdf 42522	Active Upload	500K		4H、 5L	06 on
Shuori	485	shuori BMS Modbus Protocol forR5485V1.3(2020-11-24)	MODBUS	9600	7A、 8B	1B、 2A	06 on
MUST	CAN	PV1800FCAN cormmunication Potocol1.04.04	Active Upload	500K	6H、 5L	4H、 5L	00 on
SMA	CAN	SMA-CAN V1.0.0-210630-FSS ConnectingBat-TI-en-20w	Active Upload	500K	4H、 5L	4H、 5L	00 on
MEGAREVO	CAN	Shenzhen MEGAREVO Hybrid Inverter 5K EMS Protocol V1.01	Active Upload	500K		4H、 5L	06 on
MPP Sola	485	BMS 485communication protocol20200325(2)	MODBUS	9600		1B、 2A	56 on
TuoBao	CAN	CAN BUS Protocol of TBB Lthium Battery BMS Platform V11	Active Upload	500K		4H、 5L	
Energy	CAN	SenegyINV&BMS CAN Protocols	Active Upload	500K	7H、 8L	4H、 5L	06 on
Victron	CAN	Victron-CAN-V1.00-211135	Active Upload	500K	7H、 8L	4H、 5L	00 on

2.5 INTRODUCTION TO BMS

The BMS used in the system is a protection board specially designed for 51.2V100Ah products. A BMS protection board can only control one energy storage system. The electrical schematic is as follows:

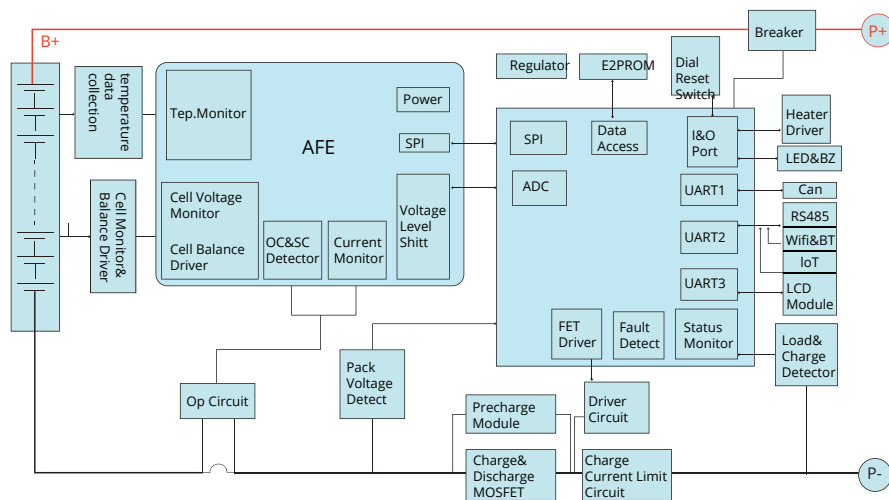

Feature description

- 1) Voltage detection and protection functions.
- 2) Cell and battery voltage detection.
- 3) Battery charge and discharge current detection.
- 4) Cell, ambient and power temperature detection.
- 5) Battery capacity calculation and cycle number function.
- 6) Charge-discharge MOSFET switching function.
- 7) Battery charge equalization function.
- 8) LED status indication function.
- 9) Intelligent key switch function.
- 10) RS485, CAN communication function.
- 11) Upper computer control function.
- 12) Charging current limit function.
- 13) Hardware voltage detection function.
- 14) Historical data storage capabilities.
- 15) Parallel communication function.
- 16) Dry contact function (optional).
- 17) Heating function (optional).
- 18) Secondary protection (optional).
- 19) Attached: Reliability parameters.

Serial Number	Project	Specifications/Conditions
1	Detection accuracy	Current accuracy: $\pm 2\%$ voltage accuracy: $\pm 20\text{mV}$ Temperature accuracy: $\pm 3^\circ\text{C}$ SOC average accuracy: $\leq \pm 5\%$
2	Current threshold	Charging current: 0.5A Discharge current: 0.5A
3	Invalidation type	1. Charge and discharge MOS tube failure; 2. Current detection failure; 3. Temperature detection failure 4. Voltage detection failure (voltage below 1.0V is prohibited from charging)
4	Information exists	Store no less than 500 historical data information, including current total voltage, current, temperature, SOC, SOH, cycle number and operating status.
5	Communication interface	1.The inverter supports CAN or RS485 communication 2.Support RS485 communication (communication port can achieve program upgrade) 3.Support RS485 parallel communication.
6	Boot	In shutdown mode, turn on the weak current switch, which can be turned on, and the LED light corresponding to the real-time SOC will be lit at the same time.
7	Shutdown	In the power-on mode, disconnect the weak current switch for 3-6S until the 6 LEDs turn off sequentially.
8	Short circuit	The internal resistance of the battery pack and short-circuit circuit is not less than $40\text{m}\Omega$, the short-circuit current does not exceed 1000A, and the air switch is short-circuited 50 times.

3. SAFE HANDLING OF LITHIUM BATTERIES GUIDE

3.1 DANGER LABEL

DANGER



DANGER
LOW DCVOLTAGE INSIDE
DANGER ARC FLASH & SHOCK HAZARD



- Do not disconnect or disassemble by non-professional personnel.
- Do not drop, deform, impact, cut or spearing with a sharp object.
- Do not place at a children or pet touchable area.
- Do not place near open flame or flammable material.
- Do not cover or wrap the product case.
- Do not touch the leaking liquid.
- Avoid of direct sunlight.
- Make sure the grounding connection set correctly before operation.
- Follow the product manual to make wiring connection.
- If leaking, fire, wet or damaged, switch off the breaker on DC side and
- Contact your supplier within 24 hours if anything failure happens.

3.2 TOOLS

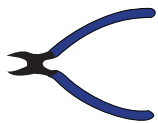

Wire cutter



Crimping modular plier

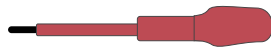

Screwdriver



NOTE

Use properly insulated tools to prevent accidental electric shock or short circuits. If insulated tools are not available, cover the entire exposed metal surfaces of the available tools, except their tips, with electrical tape.

3.3 SAFETY GEAR

It is recommended to wear the following safety gear when dealing with the battery pack .



Insulated gloves



Safety goggles



Safety shoes

4. INSTALLATION AND OPERATION

4.1 PACKAGE ITEMS

Unpacking and check the Packing List.

1) For battery module package:

Two power cables and one communication cable for each battery package (The grounding wire should be a 10AWG yellow-green cable with SC6-6 copper noses at both ends of the cable).

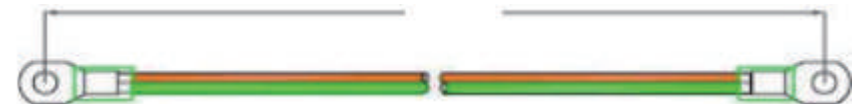
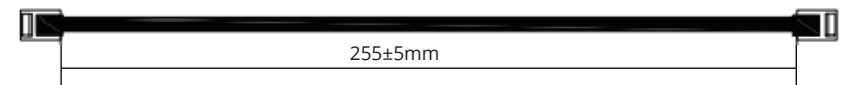
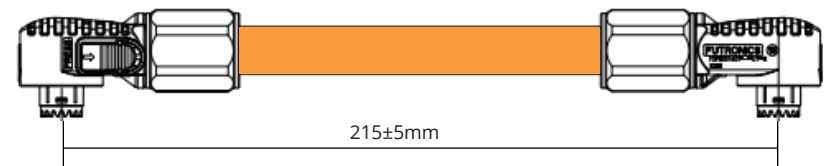
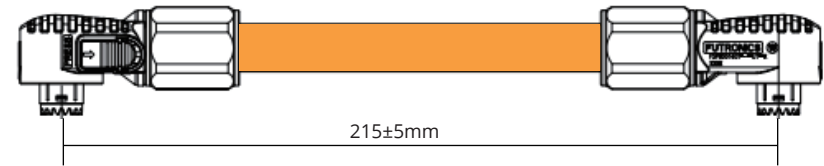

2) For battery system connects to inverters:

Each energy storage system uses two long power cables (current capacity 120a, constant 100A (25mm² SC 25-8 copper nose orange silicone wire, 25mm² SC25-8 copper nose (Black Silicone cable) and a communication cable.

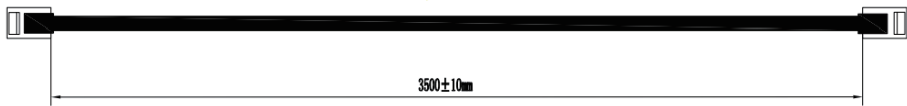
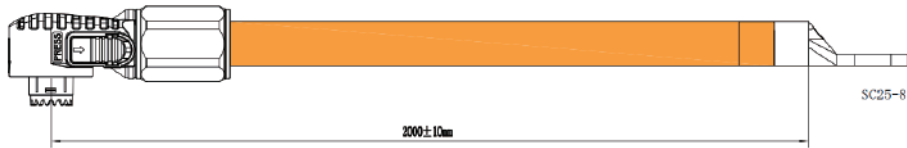
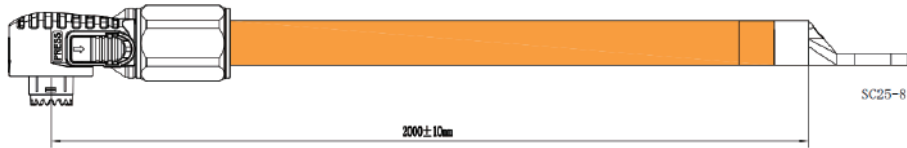

3) For master-slave communication connections:

The communication line between the host of each energy storage system and the slave is a standard network cable.

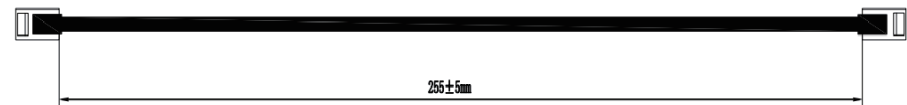

4) If the customer does not determine the installation position of the parallel cabinet or the length of the accessories, the factory accessories can provide power positive, negative output and grounding terminal accessories to facilitate the customer to match according to the actual situation on site.

Connect the orange power cable to the orange socket and the orange power cable to the black socket with a cross-sectional area of 25 square millimeters in the crimp section. Withstand voltage: DC1000V, strip conductor length: 18±1mm. Secure the back shell and check for clearance. Recommended tool: Manual hydraulic pliers (mold: 25mm²) Tensile force after crimping≥ 1200N.

If using a single battery, it is recommended that you connect either of the two battery power ports and cover the other ports with a protective cover. Parallel connection of power cables between multiple batteries, which means connecting the positive terminal of one battery to the positive terminal of the next battery, from negative to negative. Cover and protect the port of the last battery of the backup power supply.

Connect PE cable before installing equipment. Disconnect the power supply and use PE cable before disassembling the equipment. After crimping, the traction force of the cable shall be at least 400N, and any one of the two grounding cables shall be connected to the ground. Keep other grounding cables. Specification of PE cable conductor: 10awg, and the cable shall meet the outdoor use standard.

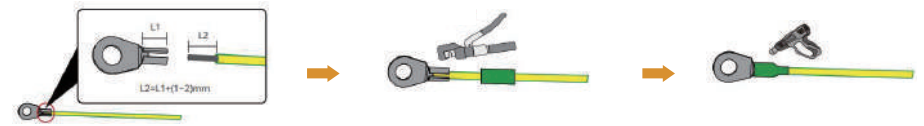

4.2 INSTALLATION LOCATION

Make sure that the installation location meets the following conditions:

- 1) The area is completely water proof.
- 2) The floor is flat and level.
- 3) There are no flammable or explosive materials.
- 4) The ambient temperature is within the range from 0°C to 50°C.
- 5) The temperature and humidity is maintained at a constant level.
- 6) There is minimal dust and dirt in the area.
- 7) The distance from heat source is more than 2 meters.
- 8) The distance from air outlet of inverter is more than 0.5 meters.
- 9) The installation areas shall avoid of direct sunlight.
- 10) There is no forced ventilation requirement for the battery module, but please avoid installing in a closed area. Ventilation shall avoid high salinity ≤ 30%, humidity ≤ 85% and ambient temperature of 0 ~ 45°C.

4.3 GROUNDING REQUIREMENTS

Grounding cables shall be 10AWG or higher yellow-green cables. After connection, the resistance from battery grounding point to Ground connection point of room or installed place shall smaller than 0.1Ω .

- 1) Based on metal directly touch between the module's surface and rack's surface. If using painted rack the corresponding place shall remove the painting.
- 2) Install a grounding cable to the grounding point of the modules.

4.4 INSTALLATION STEPS



NOTE

- ① This battery pack can only be connected in parallel.
- ② All parallel connections need to be made in the state of system down power.
- ③ Single battery pack have two positive and negative interfaces.



Single battery box

Installation steps:

1) Power cable connection

- ① Connect the positive terminal of battery pack 1 to the positive terminal of battery pack 2 with the positive terminal connection harness, when a "click" is heard, the positive terminal harness is connected and locked in place;

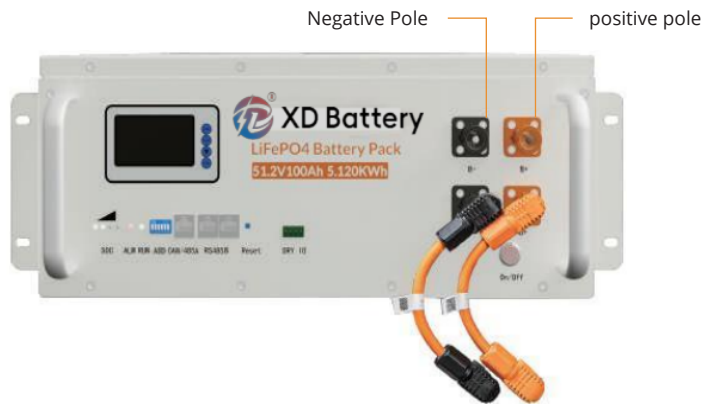

- ② Connect the negative terminal of battery pack 1 to the negative terminal of battery pack 2 with the negative terminal connection harness, and when a "click" is heard, the negative terminal harness is connected and locked in place;

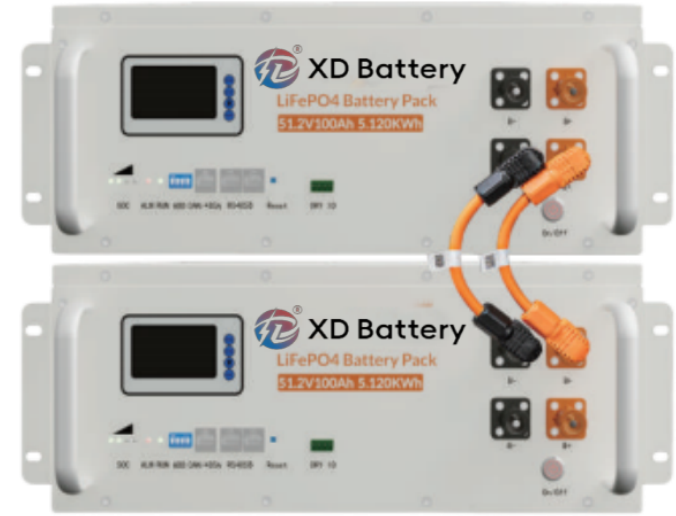

2PCS battery packs connected in parallel



3PCS battery packs connected in parallel



4PCS battery packs connected in parallel

2) Communication cable connection

Plug the RJ45 communication cable into the RS485 interface, when you hear a "click", the communication cable is connected and locked in place. When there are multiple battery packs connected in parallel, RS485/CAN port can be used as communication port.

3) Address bit dialing code

BMS can communicate with the inverter in host mode CAN, and protocol switching is realized through DIP5 and 6, and when code 6 is ON, it supports Pineng and Deye; When code 5 is ON, Pengcheng is supported; When code 5 and 6 are ON at the same time, Gorwatt is supported.

Slave setting: set according to the device order, slave address range 0 to 15, 16 parallel machines.

NO.	Dial Switch1	Dial Switch2	Dial Switch3	Dial Switch4
0	OFF	OFF	OFF	OFF
1	ON	OFF	OFF	OFF
2	OFF	ON	OFF	OFF
3	ON	ON	OFF	OFF
4	OFF	OFF	ON	OFF
5	ON	OFF	ON	OFF
6	OFF	ON	ON	OFF
7	ON	ON	ON	OFF
8	OFF	OFF	OFF	ON
9	ON	OFF	OFF	ON
10	OFF	ON	OFF	ON
11	ON	ON	OFF	ON
12	OFF	OFF	ON	ON
13	ON	OFF	ON	ON
14	OFF	ON	ON	ON
15	ON	ON	ON	ON

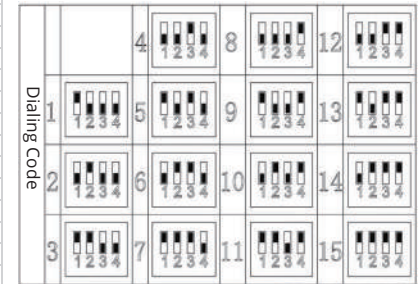

Schematic diagram of the PACK dial code

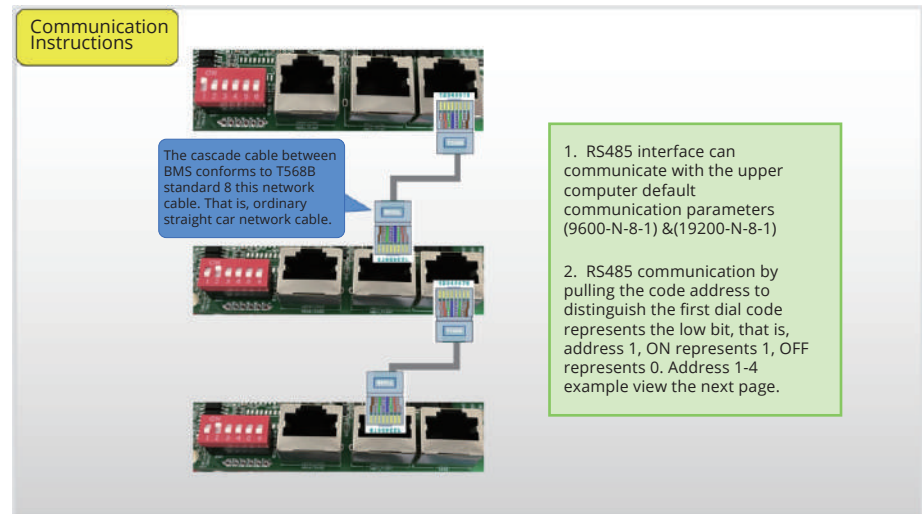

Schematic diagram of connection 1

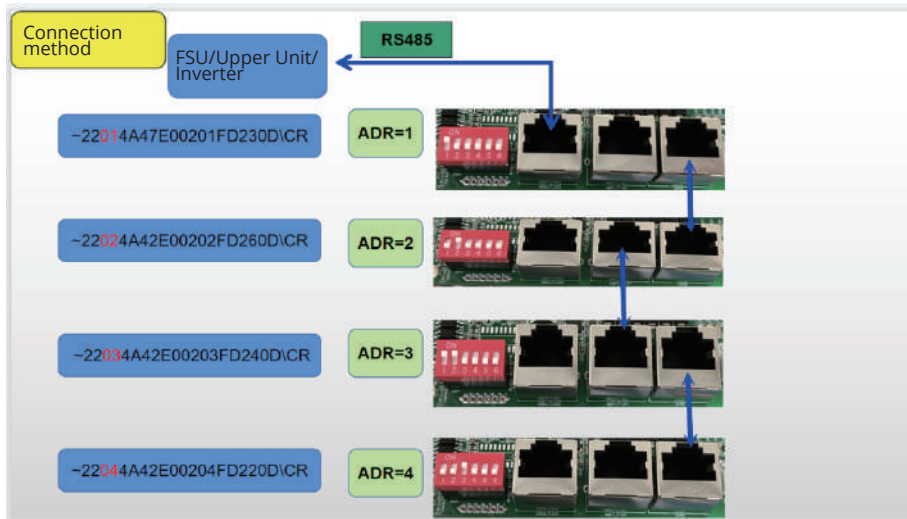

Schematic diagram of connection 2

4) Close the ON switch

Press the battery ON metal button in turn, first press the slave metal button switch, and finally open the metal button switch of the connected system host (connected to the inverter communication for the host). Finally, press the switch of the external connecting device, at this time the battery system to complete the power.

4.5 DISPLAY DESCRIPTION

Supporting backup power motherboard, can display battery pack sampling information and working status through the LCD screen. Display in white letters on blue background. Default is English.

Note: It needs to be used with film keys.

1) Key description

» : indicates a sub-menu. Press ENTER to enter the sub-menu.

Key function description

MENU : Menu key. Press this key to enter the management system.

ENTER : Confirm key. Press this key to enter the sub-menu.

▼ : Down select key. Press this key to move the cursor down or turn the page down.

ESC : Exit key. Press this key to return to the upper-level menu.



2) Display function description

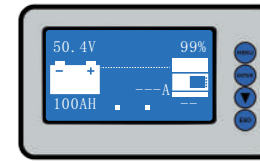

Press film

Boot interface:		NO.
System date		SOH
Charge and discharge current		Ambient temperature
Total voltage		Maximum cell temperature
Residual capacity		SOC
Maximum cell voltage		Minimum cell voltage
Note: When there is no protection status of the battery cell, the display is blank, and the opposite reports the corresponding protection status, as shown in the figure.		
Battery protection condition:		
Overvoltage		OV
Undervoltage		LV
Overtemperature		OT
Undertemperature		LT
Overcurrent		OC
Short circuit		SC

① Press MENU to access the main menu:

- BMS Parameter »
- Battery Status »
- GYRO Status »
- Uersion Number »

Figure

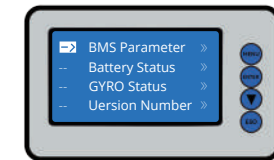

② Select the cursor to "BMS Parameter" and press to enter:

- Voltage: 0.00V
- Current: 0.0A
- GYRO Status »
- Cell Volt »

Figure

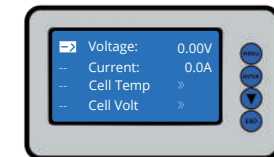

③ Select Cell Temp, press OK to enter the battery temperature information, and then press ▼ to turn the page:

- Temp01 0 °C
- Temp02 0 °C
- Temp03 0 °C
- Temp04 0 °C
- MOS Temp 0 °C
- Env Temp 0 °C

Figure

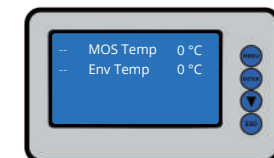
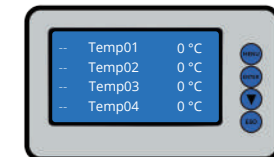

④ Select Cell Temp, press OK to enter the battery temperature information, and then press ▼ to turn the page:

```
-- Cell01      0 mV
-- Cell02      0 mV
-- Cell03      0 mV
-- Cell04      0 mV
-- Cell05      0 mV
-- Cell06      0 mV
-- Cell07      0 mV
-- Cell08      0 mV
-- Cell09      0 mV
-- Cell10     0 mV
-- Cell11     0 mV
-- Cell12     0 mV
-- Cell14     0 mV
-- Cell15     0 mV
-- Cell16     0 mV
```

Figure

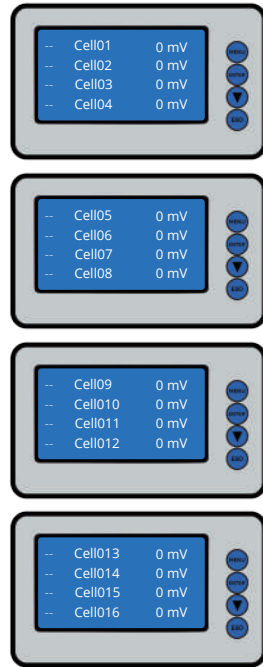

```
-- SOC          0 %
-- Nominal      0.0 Ah
-- Remain       0.0 Ah
-- BMS Cycles   0
```

Figure

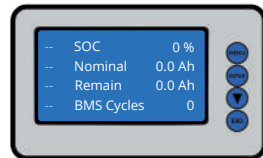

⑤ Select Battery Status, press OK to enter the battery status information, and then press ▼ to turn the page.

```
-- Status      (IDLE/DISCHG/CHARGE/FULL)
-- Alarm Status  >>
-- Protect Status >>
-- Failure Alarm >>
```

Figure

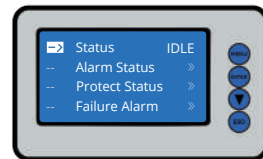

⑥ Select Alarm Status, press OK to enter the battery alarm information, and then press ▼ to turn the page.

```
-- Over Volt    YES/NO
-- Low Volt     YES/NO
-- Over Temp    YES/NO
-- Low Temp     YES/NO
-- Low SOC      YES/NO
-- Diff Volt    YES/NO
-- Over Curr    YES/NO
-- Reverse      YES/NO
```

Figure

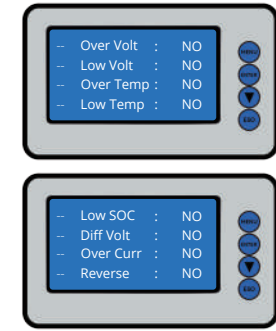

⑦ Select "Protect Status" and press "Confirm" to enter the battery protection information. Then press "▼" to turn the page.

```
-- Over Volt    YES/NO
-- Low Volt     YES/NO
-- Over Temp    YES/NO
-- Low Temp     YES/NO
-- Over Cur     YES/NO
-- Short Cu     YES/NO
```

Figure

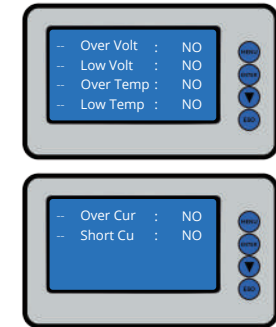

⑧ Select "Failure Alarm" and press "Confirm" to enter the battery fault information. Then press "▼" to turn the page.

```
-- Sample Line  NO/YES
-- Charge MOS   NO/YES
-- Dis CHG MOS  NO/YES
-- Sample Chip  NO/YES
-- SC Times     0
-- Over Temp CNT 0
-- Over Cur CNT 0
-- OVER Chg CNT 0
-- Over Dchg CNT 0
```

Figure

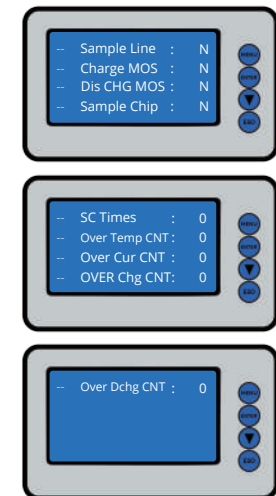

- 9) Select the cursor to "GYRO Status" and press "Confirm" to enter the gyroscope information. Then press "▼" to reverse.

-- Set X axis
-- Place Option

Note: The gyro setting function is optional.

Figure

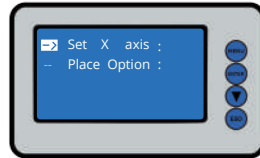

- 10) Select the cursor to "Version Number" and press "Confirm" to enter the version information. Then press "▼" to reverse the selection.

-- BMS Version »
-- LCD Version »

Figure

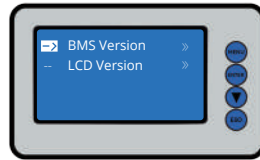

- 11) Select BMS Version and press OK to enter the BMS version information.

BMS SW Version
BMS HW Version

Figure

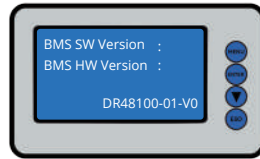

- 12) Select LCD Version and press OK to enter the LCD version information.

LCD SW Version
LCD HW Version

Figure

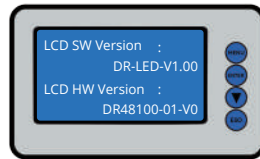

3) Hibernation and activation function

In normal operation, the display system will be in the off-screen state (only the backlight is off) after one minute without pressing a button. When the screen is off, press any key to enable the display to run normally.

4) Precautions for use

Precautions for using the display module:

- As the LCD module is assembled and adjusted with high precision, excessive impact or any change to the module should be avoided.

- Do not change the current status of the fins on the metal frame.
- Do not drill extra holes in the PCB. Change the positions of components on the PCB.
- Do not change or damage the pattern on the printed restrictor plate.
- Never change the conductive rubber strip or the heat-sealed connector.
- Do not make any changes with the soldering iron except for the welding orifice.
- Do not throw, bend or twist the module.

4.6 POWER ON

Double check all the power cable and communication cable.

- Turn on all battery module ON/OFF switches. 
- The main battery module connected to the inverter communication, and the others are slave batteries (1 main battery configuration, with a maximum of 15 slave batteries).
- Press the ON/OFF metal switch of the battery to start up, The LED indicator lights turn on successively from "run" for 0.5 seconds.
- Press the battery ON/OFF metal button in turn, turn on the slave metal button switch first, and then turn on the battery metal button switch connected to the system host. (the host connected to the inverter communication).

NOTE

After the battery module powered on, the soft-start function takes 3sec to active. After soft-starts battery ready to output high power.

Before capacity expansion, the system is powered off. During capacity expansion or replacement, when modules with different SOC / voltages are connected in parallel, please keep the system idle for ≥ 15 minutes or until SOC LEDs become similar ($\leq 1\%$).

Expansion installation sequence: see 4.4 for the expansion sequence.

4.7 POWER ON

When the BMS is in the active state, press the battery ON/OFF metal switch key (3 ~ 6S) and release it. The system will sleep, and the LED indicators will go out in turn until all LED lights go out.

NOTE

When the battery system is connected in parallel, when the single pack battery is in the following state, the single pack battery will exit the parallel and shut down, and the other batteries will continue to work.

- 1) Single or overall over discharge protection is not released within 30 seconds.
- 2) Press the key (3 ~ 6S) and release the key. (Note: after the main battery pack exits, there is no communication between the system and the inverter).
- 3) The minimum monomer voltage is lower than the sleep voltage, and the duration reaches the sleep delay time (no communication, no protection, no balance and no current).
- 4) The standby time exceeds 24 hours (no communication, no charge and discharge, no mains power).
- 5) Forced shutdown by upper computer software.
- 6) System hardware failure.
- 7) The system operating temperature exceeds the protection threshold.

Press the battery ON/OFF metal switch button (3 ~ 6S) and release it. The single battery will exit parallel connection and shut down. The single battery needs to be shut down in turn (regardless of order).

5. TROUBLE SHOOTING

5.1 PROBLEM DETERMINATION BASED ON:

- 1) Whether the battery can be turned on or not.
- 2) If battery is turned on, check the red light is off, flashing or lighting .
- 3) Check whether the system on / off light is on and whether the battery can be charged and discharged.

5.2 POSSIBLE CONDITIONS:

1) The battery cannot be turned on. Press the metal button switch, and all the lights are not on or in the standby alarm state (on / off is always on, run flashes 1, ALM flashes 3).

Capacity too low, or module over discharged.

solution:

Use a charge or inverter to provide 45.6-58.4V voltage. If battery can start, then keep charge the module and use monitor tools to check the battery log.

If battery terminal voltage is $\leq 43.2\text{Vdc}$, please use $\leq 0.05\text{C}$ to slowly charge the module to avoid affect to SOH.

If battery terminal voltage is $> 48\text{Vdc}$, it can use $\leq 0.5\text{C}$ to charge. If battery cannot start, turn off battery and repair.

2) The battery can be turned on / off and always on, but the red light is always on or flashing and cannot be charged or discharged. If the red light is always on or flashing, it indicates that the system is abnormal. Please check the following values.

Charging failure:

Overcharge protection (on / off is always on, run is always on, ALM is off, and all power indicator LEDs are always on):

Resolvent:

- ① Check whether the voltage is $> 58.4\text{V}$. If so, change the setting on the powerside. And eliminate the module.
- ② The system stops charging and sets the discharge.

3) Temperature, overcurrent and failure fault (on / off is always on, run is off, ALM is always on, and all power indicator LEDs are off).

Resolvent:

- ① Temperature: above 60°C or below -20°C , the battery cannot work. Solution: move the battery to the normal operating temperature range between 0°C and 50°C .
- ② Current: if the charging current exceeds 105A (single pack), the battery protection will be turned on. Solution: check whether the current is too large. If it is too large, change the setting on the power side.
- ③ Hardware failure: close the module and contact the local dealer for repair.

Discharge fault:

Undervoltage protection (on / off is normally on, run is off, ALM is off, and all power indicator LEDs are normally off):

Resolvent:

- ① When the battery is discharged to $< 43.2\text{v}$, the battery protection will be turned on. Charge the battery until the red light goes out.

4) Temperature, overcurrent, short circuit, reverse connection and failure fault (on / off is always on, run is off, ALM is always on, and all power indicator LEDs are off).

Resolvent:

- ① Temperature: above 55°C or below -20°C , the battery cannot work. Solution: move the battery to the normal operating temperature range between 0°C and 50°C .
- ② Current: if the discharge current exceeds 105A (single pack), the battery protection will be turned on. Solution: check whether the current is too large. If it is too large, change the setting on the power side.
- ③ Check whether the external power harness connection of the system has positive and negative reverse connection or positive and negative touch short circuit.
- ④ Hardware failure: close the module and contact the local dealer for repair.

4) On/off is normally off, run is off, ALM is normally on, and all power indicator LEDs are off. The system is permanently protected. The voltage of the single battery has been higher than 3.75V or lower than 2.5V or the temperature is higher than 80°C .

Solution:

- ① Close the module and contact your local dealer for repair.

6. EMERGENCY SITUATIONS

6.1 LEAKING BATTERIES

If the battery pack leaks electrolyte, avoid contact with the leaking liquid or gas. If one is exposed to the leaked substance, immediately perform the actions described below.

- 1) Inhalation: Evacuate the contaminated area and seek medical attention .
- 2) Contact with eyes: Rinse eyes with flowing water for 15 minutes and seek medical attention.
- 3) Contact with skin: Wash the affected area thoroughly with soap and water and seek medical attention.
- 4) Ingestion: Induce vomiting and seek medical attention.

6.2 FIRE

NO WATER! Only dry powder fire or carbon dioxide extinguisher can be used; if possible, move the battery pack to a safe area before it catches fire.

6.3 WET BATTERIES

If the battery pack is wet or submerged in water, do not let people access it, and then contact an authorized dealer for technical support. Cut off all power switch on inverter side.

6.4 DAMAGED BATTERIES

Damaged batteries are dangerous and must be handled with the utmost care. They are not fit for use and may pose a danger to people or property. If the battery pack seems to be damaged, pack it in its original container, Then return it to the authorized dealer.



Caution

Damaged batteries may leak electrolyte or produce flammable gas.

7. REMARKS

7.1 RECYCLE AND DISPOSAL

In case a battery (normal condition or damaged) needs disposal or needs recycling, it shall follow the local recycling regulation (i.e. Regulation (EC) N° 1013/2006 among European Union) to process, and using the best available techniques to achieve a relevant recycling efficiency.

7.2 MAINTENANCE

NO WATER! Only dry powder fire or carbon dioxide extinguisher can be used; if possible, move the battery pack to a safe area before it catches fire.

- 1) It is required to charge the battery at least once every 3 months, for this charge maintenance make sure the SOC is charged to higher than 90% .
- 2) Every year after installation. The connection of power connector, grounding point, power cable and screw are suggested to be checked. Make sure there is no loose, no broken, no corrosion at connection point. Check the installation environment such as dust, water, insect etc. make sure it is suitable for IP20 battery system.
- 3) If the battery is stored for long time, it is required to charge them every six months, and the SOC should be higher than 90% .